

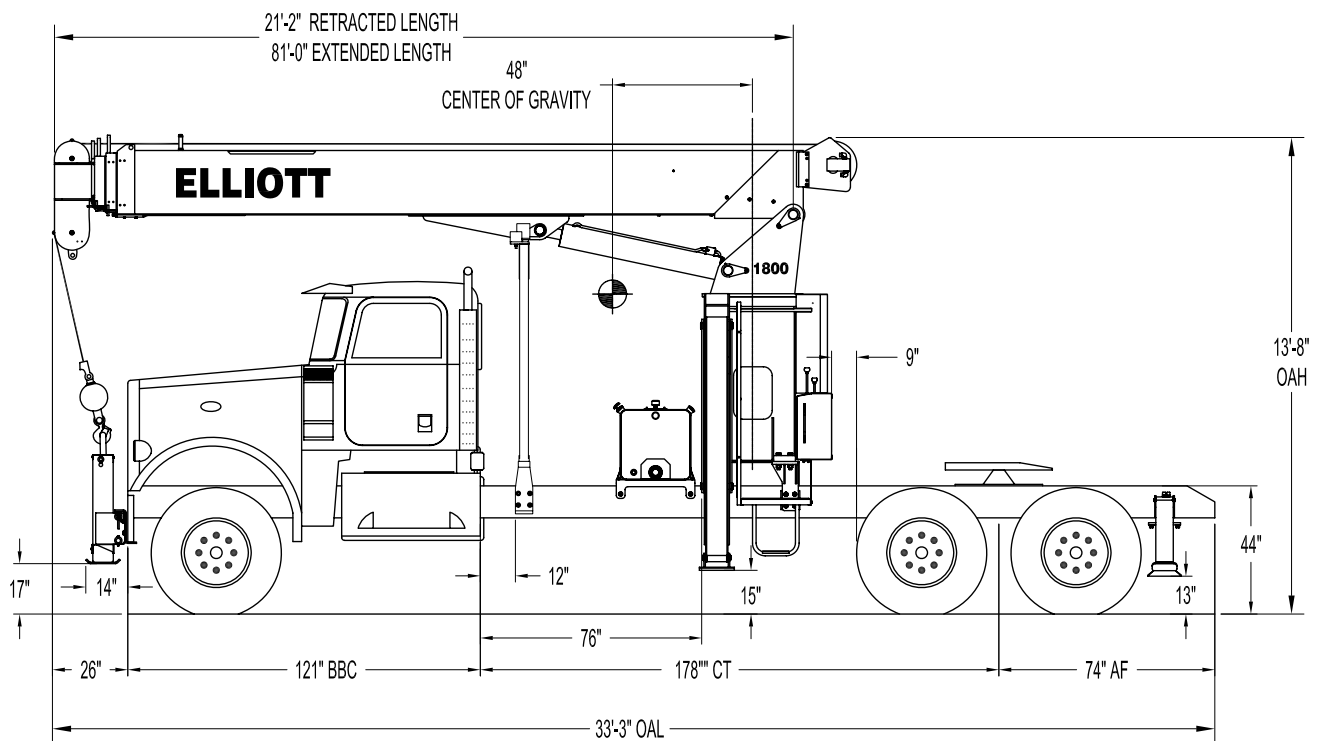

1881™ SIDE VIEW DIAGRAM



- **Maximum Vertical Reach** 121'/36,9 m
- **Working Area** 180 Degrees Standard (360 Optional)
- **Lifting Capacity** 36,000 lbs/16 329 kg
- **Boom Length** 81'/24,7 m
- **Crane Weight (Dry)** 16,420 lbs/7448 kg
- **Jib Lengths** 30'/9,1 m
- **Winch Bare Drum Pull** 12,800 lbs/5806 kg

- **Powered Boom Sections** 5
- **Overall Height** 13'8\"/>
- **Operator Controls** Dual Operator Standup Controls
- **Outrigger Type Front** A-Link
- **Outrigger Spread Front** 20'10\"/>
- **Outrigger Type Rear** A-STAB
- **Outrigger Spread Rear** 10'4\"/>

TECHNICAL SPECIFICATIONS

Crane Capacity: 36,000 lbs at five feet load radius.

Maximum Tip Height: 91' height (121' with optional 30' jib)

Control Console: Dual operator standup control stations equipped with four single axis control levers for the main crane controls. Operator station includes LMI display, bubble level gauge, engine start/stop switch, signal horn button, variable speed foot throttle, lifting capacity chart, range diagram chart, boom angle indicator, system pressure gauge, 12V DC power source, and cup holder. Outrigger lever controls at control consoles.

Boom: 21' retracted and 81' extended five-section fully proportional, high strength steel plated rectangular tube sections. A maximum boom tip height of 91' mounted on a truck. The boom nose contains one floating upper sheave and two lower sheaves. Assembly includes heavy-duty cylinder fittings, pivot pins, and replaceable wear pads.

Winch: Mounted at the base of the boom for a long fleet angle and flat level spooling of cable. Winch is driven by a planetary reducer and powered by a hydraulic motor. Burst-of-speed winch provides increased line speed. The winch brake is spring applied, pressure release design. Supplied with 275' of 9/16" wire rope with a single line pull of 9,600 pounds, and a downhaul ball with swivel hook for single part line.

Load Moment Indicator System: System senses hoist cylinder pressures, boom length and boom angle with hydraulic function lockout. The display console is equipped with a bar graph showing crane utilization, boom angle or boom length, a mode select controls for main boom and jib operation, and an anti-two block with an audio/visual warning and shut-off functions to limit hook-boom point contact.

Outriggers: One set of "A" Link main

outriggers with 20'10" span, and one set of "A" -STAB rear outriggers with a 10'4" span.

Frame: Short length, all welded rigid 4-plate design sub-frame. Tractor-mount sub-frame placed ahead of rear tandems for towing application.

Turret: Reverse offset turret is one-piece weldment. Turret rotates on large diameter ball bearing.

Rotation: Hydraulic motor drives turret through double reduction planetary swing drive for 372-degree non-continuous rotation. The swing drive system has a spring applied, pressure release brake.

Lift: One double-acting long stroke cylinder provides smooth and stable boom elevation. Holding valve prevents boom from falling in event of hose failure.

Boom Extension: Incorporates a single-stage hydraulic extension cylinder, attached to the largest boom section, with a proportional cable extension system driving the outermost section.

Hoses: All high pressure hoses are wire braid reinforced with a minimum safety factor of 4 to 1.

Cylinders: All cylinders use microhoned cylinder tubing, chrome shafts, top grade packing and protective rod wipers. Cylinder-mounted holding valves provided on all load-holding cylinders.

Hydraulic System: Equipped with cable-shift PTO, three-section gear pump, SAE O-ring face seals on pressure lines, and a 10-micron return line filter. The control valve distributes all flow to hoist system, swing circuit, and other crane functions. System is open center type.

Oil Tank Capacity: 70 gallon mounted to truck frame on roadside.

Cab Equipment: PTO cable with indicator lights installed in truck cab. U/L approved 5:BC dry chemical fire

extinguisher installed in truck cab.

Operators Manual & Video: Two CD copies and one hard copy of operation, maintenance, safety and parts manual provided with each unit. Operational and safety video provided at delivery.

Installation: Unit installed on chassis, painted, system and tank filled with oil, tested, inspected, and ready to operate.

Standard Paint: Paint turret and boom white, outriggers red, and bed and boxes black.

Bumper: Bureau of Motor Carrier Safety rear bumper.

Weight: Approximately 16,420 lbs. less truck.

Truck Chassis Required: Approx. 178" C.T. RBM 3,300,000 in-lb. per rail, 20,000 lb. front axle and 60,000 lb. GVWR required. Trucks must have front frame extension for 360 area of operation, 12V electrical system with high capacity alternator, cab clearance stop/tail/backup lights, and I.D. lamps. Recommended GVWR is minimum for BoomTruck. Contact factory when additional equipment is to be added.

Options:

18-30' Telescopic Jib.

4 Function Radio Remote Controls.

Front Stabilizer for 360 Degree Operation.

Rotation Resistant Wire Rope.

Hydraulic Tool Circuits on Bed.

Much more...

Elliott Equipment Company reserves the right to change the specification of any unit at any time without prior notice. This brochure is only a statement of general specifications on the date of this publication. For more detailed info on specific Elliott trucks go to www.elliottequip.com

LOAD CHART - MAIN BOOM, FULL-SPAN OUTRIGGERS



MODEL 1800 81-ft BOOM

MAIN BOOM LOAD RATINGS WITH FULLY EXTENDED OUTRIGGERS

MAIN BOOM LOAD RATINGS

LOAD RATINGS IN LBS. WITH OUTRIGGERS AND STABILIZERS EXTENDED

LOAD RADIUS IN FEET	LOADED BOOM ANGLE	21-ft	LOADED BOOM ANGLE	A 33-ft	LOADED BOOM ANGLE	B 45-ft	LOADED BOOM ANGLE	C 57-ft	LOADED BOOM ANGLE	D 69-ft	LOADED BOOM ANGLE	E 81-ft
5	75	36,000										
10	59	19,400	72	18,000	77	17,000						
15	40	14,600	62	13,600	70	12,000	75	11,000	78	10,200		
20			51	9,900	64	9,500	70	8,300	74	7,650	76	6,800
25			39	8,000	56	7,600	65	6,700	70	6,050	73	5,500
30					48	6,200	59	5,500	65	4,950	69	4,500
35					38	5,050	52	4,650	60	4,200	65	3,800
40					25	4,000	46	3,950	55	3,550	61	3,250
45							38	3,250	50	3,050	57	2,850
50							28	2,700	44	2,600	53	2,500
55							11	1,800	37	2,350	48	2,200
60									29	1,950	43	1,950
65											37	1,700
70											30	1,400
75											22	1,050
	0	7,450	0	3,950	0	2,200	0	1,100	0	600		
		450		300		200		150		150		100

JIB LOAD RATINGS

LOAD RATINGS IN LBS. WITH OUTRIGGERS AND STABILIZERS EXTENDED

LOAD RADIUS IN FEET	LOADED BOOM ANGLE	18 - ft JIB	LOADED BOOM ANGLE	30 - ft JIB
20	78	3,000	79.5	2,500
25	75	2,900	77	2,400
30	72.5	2,750	74.5	2,250
35	69.5	2,600	72	2,100
40	66.5	2,350	69.5	1,850
45	63.5	2,200	67	1,700
50	60	2,050	64	1,550
55	56.5	1,950	61	1,450
60	53.5	1,850	58	1,350
65	49.5	1,450	55	1,150
70	45.5	1,150	52	1,050
75	41.5	850	48.5	1,000
80	36.5	650	44.5	700

DEDUCTIONS FOR STOWED EXTENDABLE JIB (lbs.)

NOTICE

- DO NOT DEADHEAD LINE BLOCK AGAINST BOOM TIP WHEN EXTENDING BOOM

- KEEP AT LEAST 5 WRAPS OF LOADLINE ON THE WINCH DRUM AT ALL TIMES

- USE ONLY 9/16" DIAMETER WIRE ROPE, AS SPECIFIED BELOW, WITH THE PROPER BREAKING STRENGTHS LISTED

- ANTI-TWO-BLOCK SYSTEM MUST BE IN GOOD OPERATING CONDITION BEFORE OPERATING CRANE. SEE OPERATION & SAFETY MANUAL

1-PART LINE



2-PART LINE



3-PART LINE



4-PART LINE



ELLIOTT EQUIPMENT CO. SUPPLIED LOADLINE EQUIPMENT DEDUCTIONS:
 DOWNHAUL WEIGHT180 lbs
 ONE SHEAVE BLOCK.....375 lbs
 TWO SHEAVE BLOCK.....640 lbs

MAX PULL: 9,600 lbs	19,200 lbs	28,800 lbs	36,000 lbs	9/16" - 6 x 37 IWRC (3.5:1 S.F.) 33,600-lbs. BREAKING STRENGTH
MAX PULL: 9,060 lbs	18,120 lbs	27,180 lbs	36,000 lbs	9/16" - SPIN RESISTANT (5:1 S.F.) 45,300-lbs. BREAKING STRENGTH
MAX PULL: 7,680 lbs	15,360 lbs	23,040 lbs	30,720 lbs	9/16" - SPIN RESISTANT (5:1 S.F.) 38,400-lbs. BREAKING STRENGTH

CRANE MEETS ASME B30.3 REQUIREMENTS AT TIME OF MANUFACTURE

DO NOT PAINT OVER ANY LABELS 10789 10276

RANGE CHART - MAIN BOOM, FULL SPAN OUTRIGGERS



MODEL 1800 81-ft BOOM

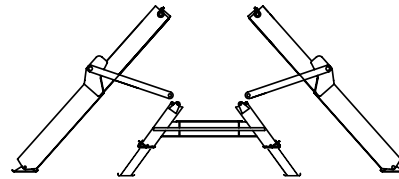
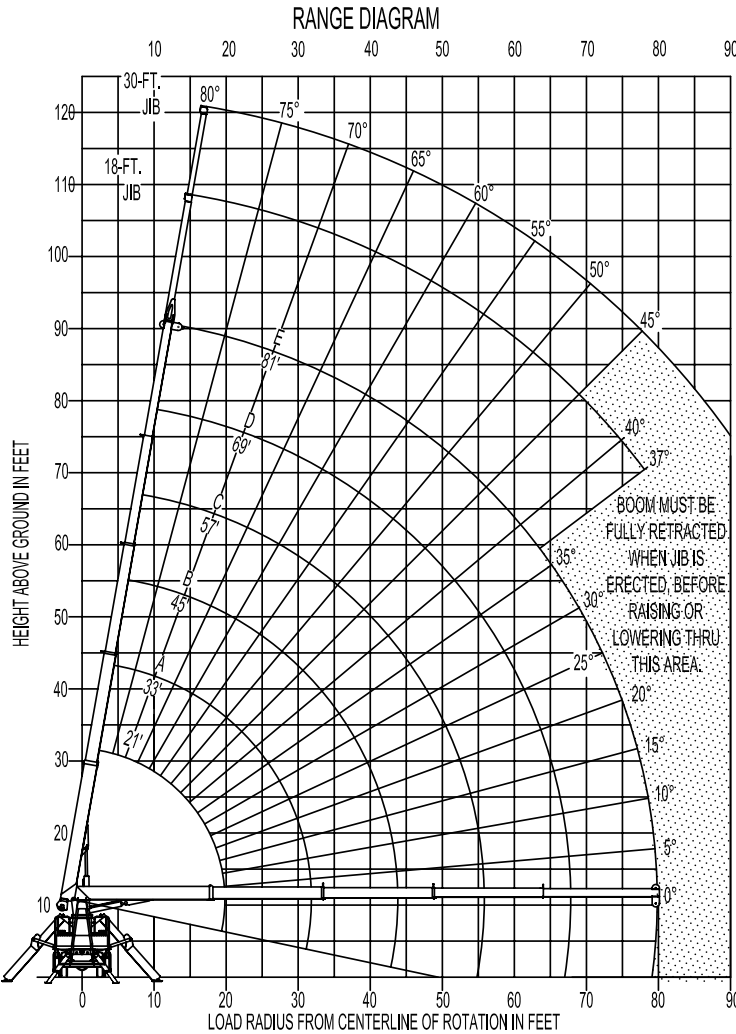

NOTE:

1. Operate jib by radius when main boom is full extended. Increase boom angle if necessary to maintain load radius.
2. When boom is retracted, operate jib by boom angles. Do not exceed any rated jib capacities at reduced boom lengths.
3. Capacities do not exceed 85% stability.
4. Load ratings above bold line are structurally limited.
5. Personnel handling is allowed only with full span outriggers.
6. Boom load ratings are based on loaded boom radius. Loaded boom angles are given as reference only.

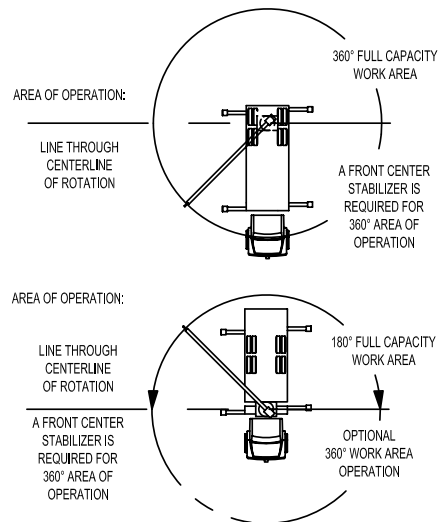

DO NOT PAINT OVER ANY LABELS 107786 10276



Elliott Equipment Company
 4427 South 76th Circle
 Omaha, NE 68127

Phone: 402-592-4500
 Fax: 402-592-4553
 Email: sales@elliottequip.com

Built for You.
www.elliottequip.com

CHASSIS SPECIFICATIONS

	1881TM BoomTruck
Wheelbase (WB)	268" / 681 cm
Cab to Tandem (CT)	178" / 452 cm
Cab to End of Frame (EOF)	295" / 749 cm
Frame Section Modulus	30.0 in3-110,000 psi / 758,428 kPa
Front Axle Gross Weight Rating	20,000 lb / 9,072 kg
Rear Axle Gross Weight Rating	40,000 lb / 18,144 kg
Integral Front Frame Rails	Required for Front Stabilizer

Chassis data is minimum general requirements-not for engineering.
 Actual dimensions and truck data will depend on truck selection and axle configuration.
 *Minimum chassis weight is required to meet 85% stability requirements.

OPTIONS



Radio Remote Control

Interference protected radio remotes let you get closer to your work and have full control over your crane.



Pin-On Jib Attachment

One piece fixed jib that stows on the side of the boom for easy placement while on the worksite.



Continuous Boom Rotation

Add the convenience of unrestricted turret rotation by selecting Elliott's continuous rotation package for turret rotation without stops.



Custom Paint

Choose from a wide list of high quality paint applications including Elliott's standard white or red paint, metallic paints, or multiple colors.



Tool Boxes

Optional tool boxes and bed storage can accommodate any storage need for tools, work materials and more.

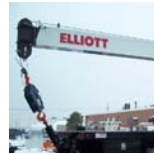

Hook Block for Multi-Part Line

Elliott can install a 2-3 part hook block or a 4 part-hook block to improve lifting capabilities. The block can be stored at the rear of the bed.



Hydraulic Oil Cooler

Add a hydraulic oil cooler and fan to assist with high duty cycle job applications. A "must" for hot weather environments



Hose Reels and Tool Circuits

Let us work with you to customize your tool compatibility by adding hose reels or hydraulic circuits to your Elliott crane.