



**RESIDENTIAL ELECTRIC WATER HEATERS
STANDARD, CASCADE, SUPER CASCADE
& ECOPEAK® TECHNOLOGY**

30 | 40 | 60 | IMP. GALLONS



**Proudly
Canadian**

Giant®

Enhancing everyday living

BENEFITS

- 1 - FACTORY INSTALLED TEMPERATURE & PRESSURE-RELIEF VALVE**
Protects the tank from the damaging effects of excessive temperature and pressure.
- 2 - FACTORY INSTALLED 3/4" NPT DI-ELECTRIC NIPPLES**
Extend the life of the water heater by providing excellent corrosion protection.
- 3 - FACTORY INSTALLED HEAT TRAPS**
Helps reduce the migration of hot water, thus limiting heat loss escaping through inlet and outlet fittings.
- 4 - AUTOMATIC TEMPERATURE CONTROL**
Adjustable thermostats will provide years of reliable trouble-free service at the desired water temperature and a safety cut-off is provided for abnormal conditions.
- 5 - INSULATION**
A thick uniform blanket of **GREENFOAM** eco-friendly insulation keeps the water hotter for longer periods, reduces stand-by losses and energy costs. **GREENFOAM** contains no HCFC'S (hydrochlorofluorocarbons), CFC'S (chlorofluorocarbons), HFC'S (hydrofluorocarbons) nor VOC'S (volatile organic compounds).
- 6 - ELECTRIC ELEMENTS**
All models are equipped with CSA approved bolt-on immersion elements made by Giant. These elements can be easily replaced with no special tools, resulting in low maintenance costs.
- 7 - GLASS-LINED INNER TANK**
A uniquely formulated blue cobalt glass enriched with zircon is fused to specially treated steel at 1,600°F (871°C) to provide the best coating available against corrosion for many years. The tank is certified at a test pressure of 300 PSI (2,068 kPa) and a working pressure of 150 PSI (1,035 kPa).
- 8 - HIGH QUALITY MAGNESIUM ANODE**
Provides excellent protection against the corrosive effects of water and extends tank life.
- 9 - DRAIN VALVE**
Tamper-resistant, one-piece drain valve is installed for easy drainage.
- 10 - OVERFLOW SYSTEM**
A 90° elbow overflow tube is supplied with each residential electric water heater.

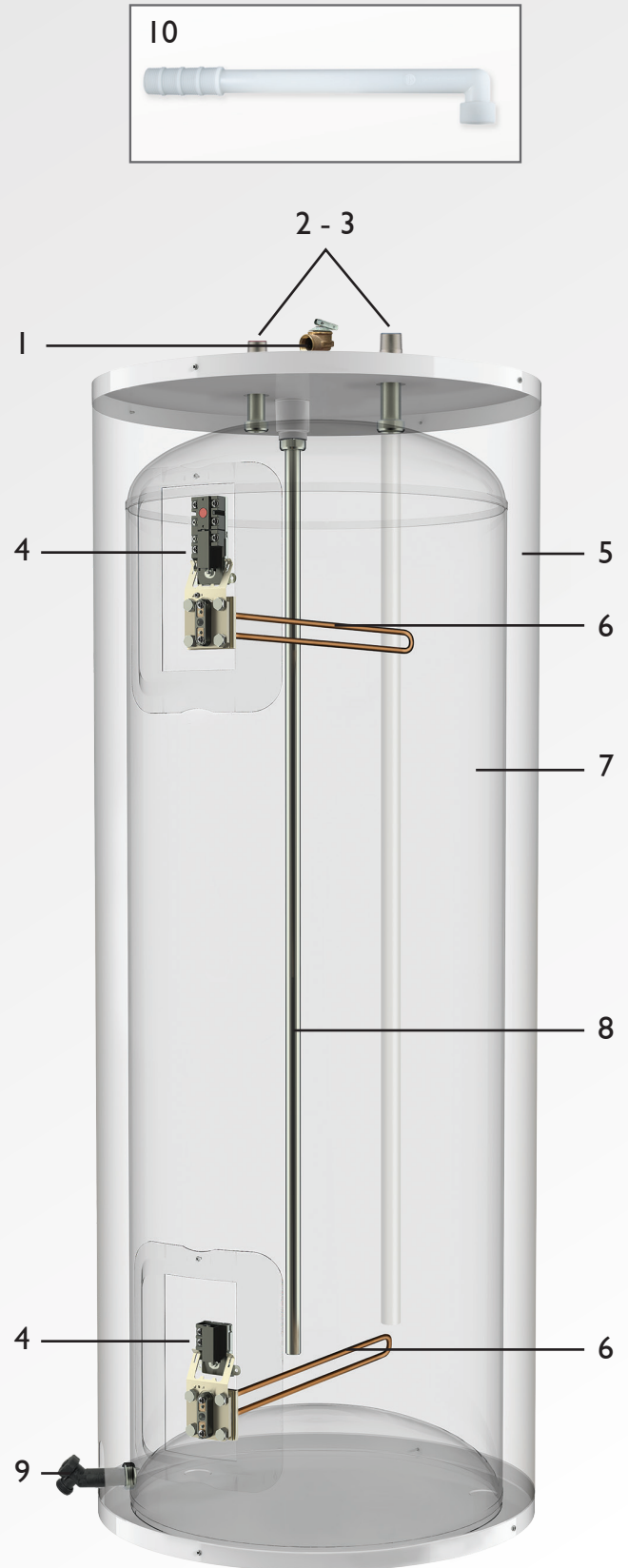

Standard

STANDARD MODELS

WARRANTY
6 years | **1** year
against inner tank leakage | on component parts



Inside View



60 gallons

30 gallons

40 gallons

	Standard	Cascade	Super Cascade
eco-friendly insulation	✓	✓	✓
Di-electric nipples	✓	✓	✓
Magnesium anode	Normal	Normal	Oversized
Low watt density elements	—	✓	✓
Rustproof glass-lined inner coating – blue cobalt glass enriched with zircon	Single coating	Single coating	Double coating
Tamper-resistant drain valve	Plastic	Plastic	Brass
Automatic temperature control	✓	✓	✓
Safety valve – Factory installed	✓	✓	✓
90° horizontal overflow elbow tube	✓	✓	✓
Vertical evacuation tube	—	—	✓
Bottom cold water entry	—	✓	✓
10% more hot water	—	✓	✓
Warranty against inner tank leakage	6 years	8 years	10 years
Warranty on component parts	1 year	5 years	5 years

CASCADE & SUPER CASCADE MODELS

COLD WATER INTAKE

TOP ENTRY

Cold water eddies down and cools the hot water at the bottom of the tank.

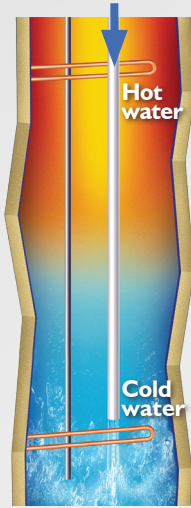

Standard

BOTTOM ENTRY

Cold water stays at the bottom of the tank until it heats up.

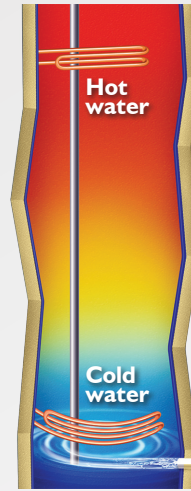

Bottom entry
10% more hot water



BENEFITS

Cascade models offer most features of the Standard models plus:

- **Low watt density elements**
For longer element life.
- **Bottom water entry**
Allowing to have 10% more hot water.
- **Warranty against inner tank leakage**
Limited warranty of EIGHT (8) years against inner tank leakage from the date of installation.
- **Warranty on component parts**
Limited warranty of FIVE (5) years on heating elements. Limited warranty of ONE (1) year on thermostats.

WARRANTY
8 years against inner tank leakage | **5 years** on component parts



BENEFITS

Super Cascade models offer most features of the Standard and Cascade models plus:

- **Oversized magnesium anode**
High quality.
- **Double coating of blue cobalt glass**
Protects the inner tank against corrosion and perforation.
- **Brass safety drain valve**
For easy drainage.
- **Vertical evacuation tube**
Provided to facilitate the redirection of water to the retention tank.

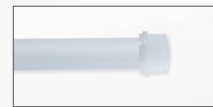

- **Warranty against inner tank leakage**
Limited warranty of TEN (10) years against inner tank leakage from the date of installation.
- **Warranty on component parts**
Limited warranty of FIVE (5) years on heating elements. Limited warranty of ONE (1) year on thermostats.

WARRANTY
10 years against inner tank leakage | **5 years** on component parts



MODELS WITH **ECOPEAK** TECHNOLOGY

TRIED AND TESTED TECHNOLOGY

A two-year pilot project was conducted with 75 households to evaluate the three-element water heater's performance. The study showed that customers do not see any difference in quality between the two-element model and the new environmentally responsible water heater. In fact, the three-element model is more reliable, since there is less stress on its electric components.

Unlike traditional two-element water heaters, whose power demand is concentrated during peak periods, three-element heaters draw less power and spread energy consumption throughout the day.

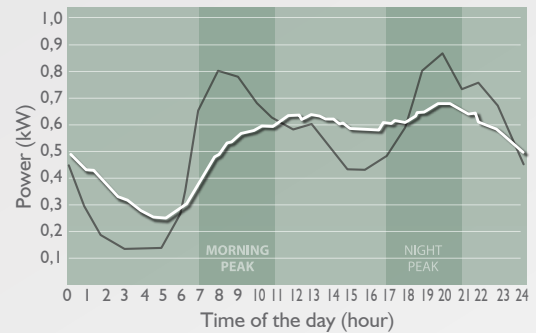

BENEFITS

The top element (3,800 Watts)

Operates alternately with the two other elements to heat water in the upper part of the tank.

The middle element (3,000 Watts)

Operates when needed with the bottom element to heat water over a short period of time.

The bottom element (800 Watts)

Operates almost continuously at a very low wattage.

ADVANTAGES

- ✓ A sustainable choice that lowers the collective electricity demand during peak periods.
- ✓ Price comparable to that of traditional two-element water heaters.
- ✓ No difference in your electricity costs.
- ✓ No impact on hot water availability.
- ✓ Less stress on electrical components, extends service life and increases reliability.

Standard

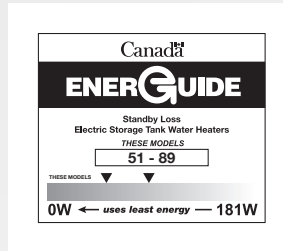
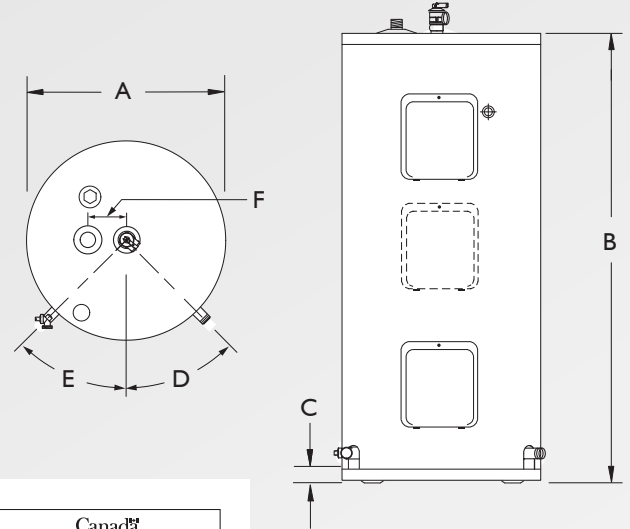
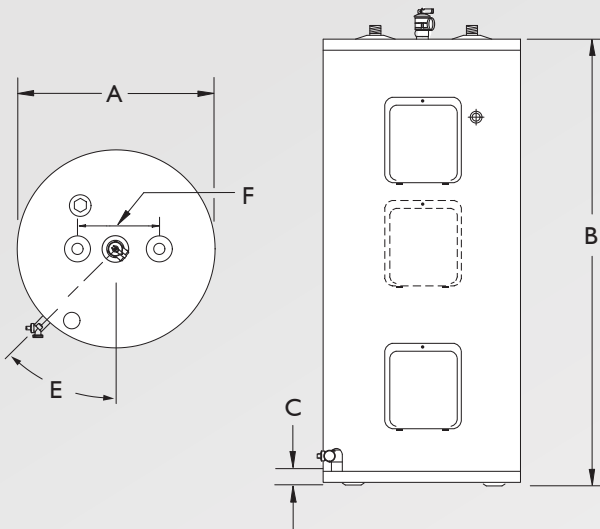

SPECIFICATIONS & DIMENSIONS

Models	Storage Capacity			Factory installed wattages						Standby loss	Diameter (A)		Height (B)		C	D	E	F	Estimated ship. weight			
	U.S. (gal.)	Litre	Imp. (gal.)	120 V		208 V		240 V			inches	(cm)	inches	(cm)					inches	(cm)	inches	(cm)
STANDARD																						
I42STE	36	135	30	1,500	12.5	3,000	14.4	3,000	12.5	51	22	(56)	36 1/4	(92)	2 1/2	(6)	—	45°	8	(20)	115	(52)
I52STE	49	184	41	1,500	12.5	3,000	14.4	3,000	12.5	62	22	(56)	49 1/4	(125)	2 1/2	(6)	—	45°	8	(20)	140	(64)
I72STE	74	279	61	1,500	12.5	4,500	21.6	4,500	18.8	78	24	(61)	59 7/8	(152)	2 1/2	(6)	—	45°	8	(20)	185	(84)
CASCADE & SUPER CASCADE																						
I52B,E*	49	184	41	1,500	12.5	3,000	14.4	3,000	12.5	66	22	(56)	49 1/4	(125)	2 1/2	(6)	45°	45°	4	(10)	140	(64)
STANDARD, CASCADE & SUPER CASCADE equipped with ECOPEAK™ technology																						
Models	Storage Capacity			Element input (240 Volts)**				Standby loss	Diameter (A)		Height (B)		C	D	E	F	Estimated ship. weight					
	U.S. (gal.)	Litre	Imp. (gal.)	Top Watts	Middle Watts	Bottom Watts	Max. Amp.		inches	(cm)	inches	(cm)					inches	(cm)	inches	(cm)	lb	(kg)
I72STPS	74	279	61	3,800	3,000	800	15.8	78	24	(61)	59 7/8	(152)	2 1/2	(6)	—	45°	8	(20)	185	(84)		
I72BPS, EPS	74	279	61	3,800	3,000	800	15.8	89	24	(61)	59 7/8	(152)	2 1/2	(6)	45°	45°	4	(10)	185	(84)		

Toxic chemicals, such as those used for boiler treatment, must NEVER be introduced into this system. These units must NEVER be connected to any existing heating system or component(s) previously used with a non-potable water heating appliance. *British-Colombia requirements may differ, please contact your local provider. **Also available in 208 Volts.

<p>STANDARD</p> <p>WARRANTY</p> <p>6 years 1 year</p> <p>against inner tank leakage on component parts</p>	<p>CASCADE</p> <p>WARRANTY</p> <p>8 years 5 years</p> <p>against inner tank leakage on component parts</p>	<p>SUPER CASCADE</p> <p>WARRANTY</p> <p>10 years 5 years</p> <p>against inner tank leakage on component parts</p>
--	--	---

Giant offers a SIX (6) year limited warranty on residential electric **STANDARD** water heaters against inner tank leakage from the date of installation. ONE (1) year limited warranty on component parts.

Giant offers an EIGHT (8) year limited warranty on residential electric **CASCADE** water heaters against inner tank leakage from the date of installation. FIVE (5) year limited warranty on component parts.

Giant offers a TEN (10) year limited warranty on residential electric **SUPER CASCADE** water heaters against inner tank leakage from the date of installation. FIVE (5) year limited warranty on component parts.

For more specific warranty details including exceptions, consult the owner's manual that comes with each water heater.

In accordance with our company policy of on-going product improvement, Giant Factories Inc. reserves the right to make changes without prior notice.

Giant[®]

Enhancing everyday living

A family company since 1945.

40 Lesage Avenue, Montréal-East, Québec, H1B 5H3 CANADA
 Telephone: 514-645-8893 • Toll free: 1-800-363-9354
 General fax: 514-640-0969
 Customer Service fax: 514-645-8413

www.giantinc.com